



January 7, 2020

Chairwoman Christy McCormick  
Vice Chair Benjamin Hovland  
U.S. Election Assistance Commission  
1335 East West Highway, Suite 4300  
Silver Spring, Maryland 20910  
[cmccormick@eac.gov](mailto:cmccormick@eac.gov)  
[bhovland@eac.gov](mailto:bhovland@eac.gov)

**RE: Request to investigate ES&S for misrepresentations regarding EAC certification of voting machines with modems**

Dear Chairwoman McCormick,

We write to you to request that the Election Assistance Commission (EAC) initiate an inquiry and investigation into Elections Systems & Software (ES&S). ES&S may have violated, and likely continues to violate, Sections 5.14 and 5.15.1 of the EAC Testing and Certification Program Manual Version 2.0 (May 31, 2015) (TCPM)<sup>1</sup> by representing or implying that the DS200 with modem configuration is EAC certified when in fact only the DS200 *without* modem is EAC certified.<sup>2</sup> ES&S also may have violated Section 5.16 by failing to warn purchasers that adding an uncertified modem to the DS200 will void the EAC certification of the voting system in its entirety. The EAC should investigate this misconduct, require corrective action, and determine whether to suspend ES&S's manufacturer registration.

---

<sup>1</sup> Election Assistance Commission, Testing & Certification Program Manual v.2 (May 31, 2015), available at <http://bit.ly/2tzHgQq>.

<sup>2</sup> ES&S EVS 5.0.0.0 Certificate of Conformance, available at <http://bit.ly/352lkLq> (May 16, 2013). The ES&S EVS 5.0.0.0 Certificate of Conformance and all documents cited hereafter relating to the certification of the EVS 5.0.0.0 are available at <https://www.eac.gov/voting-equipment/evs-5000/>.

## 1. Background

ES&S manufactures the DS200, a precinct-based ballot scanner and vote tabulator. The EAC certified the DS200 without a modem in 2009, under the Voluntary Voting Systems Guidelines Version 1.0 (VVSG 1.0) as part of the certification of the ES&S Unity 3200 system.<sup>3</sup> In 2011, ES&S submitted a new voting system, the EVS 5.0.0.0, to the EAC for certification. As part of the EVS 5.0.0.0 system, ES&S sought certification of the DS200 as a stand-alone precinct scanner, as a precinct scanner with wired modem capability, and as a precinct scanner with wireless network capability. The testing agency subsequently developed a draft certification test plan to test all three versions of the DS200.<sup>4</sup> However, on August 13, 2012, ES&S withdrew both the wired modem and wireless transmission configurations of the DS200 from their application process.<sup>5</sup> Thereafter, the testing agency revised its test plan and tested the EVS 5.0.0.0 system, including the DS200 only as a stand-alone precinct scanner.<sup>6</sup> This version of the EVS 5.0.0.0 system—which does not include either a wired modem or wireless transmission configuration of the DS200—was certified by the EAC to VVSG 1.0 standards on May 13, 2013.<sup>7</sup> Since initial certification, it is our understanding that ES&S has not submitted a wired modem or wireless configuration of the DS200 for EAC testing or certification.

## 2. Misrepresentations

Despite withdrawing the wired modem and wireless configurations of the DS200 from the certification process, ES&S continues to offer the modem configuration as an optional add-on to the DS200. Through a “product one-sheet” currently available on the ES&S website and appended to this letter as Attachment A, ES&S identifies the DS200 “optional wireless modem results transfer with

---

<sup>3</sup> iBeta Quality Assurance, “Election Systems & Software Unity 3.2.0.0 Voting System VSTL Certification Test Report (2009), available at <https://www.eac.gov/documents/2009/7/22/ess-unity-3200-test-report-ver-40-ibeta/>.

<sup>4</sup> Wyle Laboratories, Certification Test Plan, Certification Test Plan No. T59087.01, Manufacturer System EVS 5.0.0.0 (March 22, 2012).

<sup>5</sup> Steve Pearson, Vice President, Certification, ES&S, Letter to U.S. Election Assistance Commission Re: EVS 5.0.0.0 Scope Revision (August 13, 2012).

<sup>6</sup> Wyle Laboratories, Certification Test Plan, Certification Test Plan No. T59087.01 REV D, Manufacturer System EVS 5.0.0.0 (March 22, 2012).

<sup>7</sup> ES&S EVS 5.0.0.0 Certificate of Conformance; Alice P. Miller, U.S. Election Assistance Commission, Letter to Steve Pearson, Vice President, Certification, ES&S, Re: Agency Decision—Grant of Certification (May 16, 2013); Wyle Laboratories, Test Report, Report No. T59087.01-01 Rev A (May 1, 2013).

encryption” as an example of the scanner’s “comprehensive” key features.<sup>8</sup> ES&S also distributes the one-sheet, past versions of the one-sheet, and similar materials to potential buyers, including Cuyahoga County, Ohio (2018),<sup>9</sup> South Dakota (2018),<sup>10</sup> Tioga County, Pennsylvania (2019),<sup>11</sup> North Carolina (2019),<sup>12</sup> and Boone County (2019).<sup>13</sup> ES&S also has produced and disseminated at least one other similar DS200 brochure, appended to this letter as Attachment B, including to Grand Traverse, Michigan.<sup>14</sup> It is our understanding that ES&S has produced and distributed these one-sheets and similar promotional materials, featuring both the “EAC certified” logo and the wireless modem as an available option, since approximately 2016, and possibly earlier.

### 3. Violations of the Testing and Certification Program Manual

ES&S’s advertisements violate Sections 5.14 and 5.15.1 of the TCPM by falsely stating or implying that the DS200, when purchased with the optional wireless modem, is certified to EAC standards. The EAC requires that manufacturers accurately display its mark of certification and avoid misleading potential buyers into believing that a system, or any component thereof, is certified when it is not.

---

<sup>8</sup> See ES&S “DS200 Precinct Scanner & Tabulator” (2016), *available at* [https://www.essvote.com/wp-content/uploads/2019/07/DS200\\_One-Sheet.pdf](https://www.essvote.com/wp-content/uploads/2019/07/DS200_One-Sheet.pdf) (last visited Dec. 11, 2019). As of December 11, 2019, the document can be found by visiting the DS200 product page on the ES&S website, *available at* <https://www.essvote.com/products/ds200/>, where ES&S provides the “product one-sheet” as a download.

<sup>9</sup> ES&S, “Cuyahoga County, Ohio Tabulation Equipment Survey” p. 103-04 (Nov. 9, 2018), *available at* <http://bit.ly/33Wa6al>.

<sup>10</sup> ES&S Information Sheets, DS200 Product One-Sheet at p.3-4, *available at* <http://bit.ly/33ScZJ9>.

<sup>11</sup> ES&S DS200 Product One-Sheet, *available at* <http://bit.ly/2RJRdVo>.

<sup>12</sup> ES&S DS200 Product One-Sheet, *available at* <http://bit.ly/362eJko>. The document can be found with other ES&S materials provided to the North Carolina State Board of Elections (NC SBE), which can be found and downloaded through the NC SBE, *at* [https://dl.ncsbe.gov/index.html?prefix=State\\_Board\\_Meeting\\_Docs/2019-07-28/Certification/Voting%20System%20Certification/ESS/](https://dl.ncsbe.gov/index.html?prefix=State_Board_Meeting_Docs/2019-07-28/Certification/Voting%20System%20Certification/ESS/).

<sup>13</sup> ES&S DS200 Product One-Sheet, included in Boone County Commission proceedings at 300-01 (July 16, 2019), *available at* <http://bit.ly/34f58Fw>. *See id.* at pp. 99-342 (documents related to Boone County purchase of ES&S equipment)

<sup>14</sup> DS200 Product Brochure, *available at* <http://bit.ly/36nZXVl>.

TCPM Section 5.14 provides that:

Manufacturers may not represent or imply a voting system is EAC certified unless it has received a Certificate of Conformance for the system. Statements regarding EAC certification in brochures, on websites, on displays, and in advertising/sales literature must be made solely in reference to specific systems. Any action by a Manufacturer to suggest EAC endorsement of its product or organization is strictly prohibited and may result in a Manufacturer's suspension or other action pursuant to Federal civil and criminal law. Manufacturers must provide a copy of the Certificate and Scope of Certification document (found at [www.eac.gov](http://www.eac.gov)) to any jurisdiction purchasing an EAC certified system.<sup>15</sup>

Under Section 5.15.1, the TCPM also provides that:

The Manufacturer may use only the Mark of Certification that accurately reflects the certification held by the voting system as a whole. The certification of individual components or modifications shall not be independently represented by a Mark of Certification. In the event a system has components or modifications tested to various (later) version of the VVSG, the system shall bear only the Mark of Certification of the standard to which the system (as a whole) was tested and certified (i.e. the lesser standard). Ultimately, a voting system shall only display the Mark of Certification of the oldest or least rigorous standard to which any of its components are certified.<sup>16</sup>

Pursuant to Section 5.16, the TCPM also requires that “[t]he user’s manual or instruction manual for a certified voting system shall warn purchasers that any changes or modifications to the system not tested and certified by the EAC will void the EAC certification of the voting system.”<sup>17</sup>

ES&S has not followed the standards set forth in the TCPM. It displays the mark of certification on its website page for the DS200 and on other advertising materials sent or otherwise made available to election officials. The advertisements

---

<sup>15</sup> EAC Testing and Certification Program Manual Version 2.0 § 5.14 (May 31, 2015) (hereinafter “TCPM”).

<sup>16</sup> TCPM § 5.15.1 (emphasis added).

<sup>17</sup> TCPM § 5.16 (emphasis added).

clearly indicate to buyers that the DS200—alone or with its optional features, including the modem—is fully certified by the EAC. Election officials easily could be misled into purchasing the DS200 with a wireless modem configuration, not realizing that the modem is uncertified, and that under Section 5.15.1 and Section 5.16, the modem’s addition to the DS200 would void its certification and indeed, would void the certification of the entire system.

ES&S may also be misrepresenting the modem as certified throughout the procurement process, which may qualify as an additional violation of the TCPM. In 2014, for example, in response to the Maryland State Board of Elections Request for Proposal (RFP) for an election system, ES&S submitted a proposal for its EVS 5.2.0.0, which Maryland accepted.<sup>18</sup> It is our understanding that during the procurement process, ES&S proposed the addition of a modem to the DS200 without indicating that its addition would void the system’s EAC certification. Ultimately, after providing Maryland with a more expensive version of the EVS that included DS200 with modems, ES&S had to refund \$1.2 million to the state of Maryland and remove modems from the already distributed machines.<sup>19</sup> ES&S may well have violated Section 5.16 by failing to warn the Maryland State Board of Elections that installing the modems in the DS200 voided the system’s certification.

In Rhode Island, ES&S submitted a proposal in response to the state’s RFP for a new voting system.<sup>20</sup> In its proposal, ES&S repeatedly claimed that its voting system, the EVS 5.2.0.3, was EAC certified.<sup>21</sup> Although it acknowledged that modem transmissions were not part of the EAC certification process, ES&S did not

---

<sup>18</sup> Maryland State Board of Elections Request for Proposals, No. D38B4400019 (July 22, 2014); State of Maryland State Board of Elections, Meeting Minutes—October 30, 2014, at p. 9, available at <http://bit.ly/2PAtaWj>.

<sup>19</sup> State of Maryland State Board of Elections, Meeting Minutes—July 17, 2015, at p. 5-6, available at <http://bit.ly/36rGmUo>; State of Maryland State Board of Elections, Meeting Minutes—August 27, 2015, at p. 4, available at <http://bit.ly/38DLkPM>.

<sup>20</sup> ES&S, “Enhancing the Election Process for the State of Rhode Island: Request for Proposal RFP #9549934 Voting Equipment System (Oct. 30, 2015) (hereinafter ES&S Rhode Island Proposal). Relevant excerpts are appended to this letter as Attachment C, and we have made the entire document available on the Free Speech For People website, at <http://bit.ly/2LIMFLh>.

<sup>21</sup> *Id.* at 9 (“Certified Proven Products—ES&S is bidding the proven DS200 precinct based scanner.”); *id.* at 55 (“Designed and federally certified to meet the rigorous security standards of the 2005 Voluntary Voting Systems Guidelines, the operating system controls, limits, and detects unauthorized access to all critical system components.”); *id.* at 117 (“The proposed version of the DS200 is the latest version of the DS200 which is certified to the U.S. EAC VVSG 2005 standard . . .”).

disclose that use of non-certified components will void the entire system's EAC certification.<sup>22</sup> ES&S also submitted a diagram that coded the DS200 with internal wireless modem as being part of the "EAC Certified Configuration."<sup>23</sup> Furthermore, though the diagram showed a system that integrated EAC-certified and non-certified components, ES&S did not clarify that under EAC guidelines, inclusion of any non-certified component in a voting system would void the entire system's certification. ES&S may well have violated Section 5.15.1, as well as 5.16 by failing to disclose to the Rhode Island Board of Elections that the EVS 5.2.0.3 may no longer be EAC certified if used with the DS200 with internal modems.

The TCPM correctly recognizes that an election technology manufacturer cannot be allowed to falsely claim certification that its systems have not earned. And ES&S's omissions in its advertisements and procurement-related communications do precisely this. Though the EVS 5.0.0.0 and its subsequent versions are certified, inclusion of the uncertified modem voids the entire system's certification. ES&S clearly violates the TCPM by omitting this information from its advertisements and its procurement communications.

Courts throughout the country have long recognized that omission of material facts may void contracts and give rise to cognizable claims for damages against the omitting party. As the Supreme Court recently confirmed, "[b]ecause common-law fraud has long encompassed certain misrepresentations by omission, 'false or fraudulent claims' include more than just claims containing express falsehoods . . . misrepresentations by omission can give rise to liability."<sup>24</sup> Omission of critical information about "statutory, regulatory, or contractual requirements" may well result in "misleading half-truths" that give rise to cognizable claims of fraudulent misrepresentation.<sup>25</sup>

But counties and states should not have to resort to contract disputes with election vendors. They must be able to trust the accuracy of vendor assurances about EAC certification.

---

<sup>22</sup> See *id.* at 49 (noting that modem transmissions were not part of the EAC certification process).

<sup>23</sup> *Id.* at 166-67.

<sup>24</sup> *Universal Health Servs., Inc. v. United States*, 136 S. Ct. 1989, 1999 (2016).

<sup>25</sup> *Id.* at 2001. Though federal contract law does not govern ES&S's fraudulent misrepresentations, omission of material fact is recognized as a form of fraud in states throughout the country, including those in which ES&S has contracted.

#### 4. Requested action

The EAC should rigorously apply its standards and protections, and take swift response where vendors make false and misleading claims. Section 5.15.4 of the Testing and Certification Program Manual provides a broad range of remedies for vendor misrepresentation of certification status, including requiring corrective action, decertification, and manufacturer suspension.<sup>26</sup>

If the EAC determines a voting system is not in compliance with the VVSG, and the system has already been sold or otherwise distributed bearing the Mark of Certification, the EAC shall provide written notice to the Manufacturer. If the Manufacturer fails to take corrective action within 15 days of receipt of such notice, the EAC shall have the right to announce publicly that the voting system may no longer comply with its original certification, and may choose to initiate decertification actions as outlined in Chapter 7 of the *Manual*, and/or suspension of Manufacturer Registration as outlined in Section 2.6 of the *Manual*. Corrective action may include modification of the voting system to bring it into compliance with the VVSG, or removal of the Mark of Certification from the product.

(Section 5.15.4)

For this reason, we strongly urge the EAC to investigate ES&S's alleged violations of Sections 5.14, 5.15.1, and 5.16. And if ES&S requests an opportunity to cure its violations, the EAC should require substantive action on the vendor's part. Simply removing the advertisements or adding curative language is necessary, but not sufficient. ES&S must take proactive steps to correct its error, including but not limited to negotiating with parties that have purchased the equipment to reach an appropriate settlement of damages; running public advertisements in all states that have, or are considering the purchase of the DS200, to acknowledge and correct the omissions; and conducting public forums for voters who have had to, or may have to, vote on modem-equipped DS200 machines. Furthermore, the EAC should subject ES&S to rigorous overview of its advertisements for such period of time as necessary to reassure voters throughout the country that ES&S has learned to accurately advertise its certifications. Finally,

---

<sup>26</sup> Section 2.6 provides that “[w]hen Manufacturers violate the certification program’s requirements by engaging in management activities inconsistent with this Manual or failing to cooperate with the EAC, their registration may be suspended until such time as the issue is remedied.” Under Section 2.6.2, suspension of registration means that “[a] suspended Manufacturer may not submit a voting system for certification.”

the EAC should reserve the right, based on information derived from its investigation or if ES&S is any way uncooperative, to suspend the company's registration indefinitely.

States and counties across the country rely upon the EAC certification process to guide their choice in voting systems and vendors. And the EAC correctly requires vendors to advertise certification only when *all* components of the advertised system has been thoroughly tested and certified by the EAC. Rules 5.14, 5.15.1, and 5.16 are important rules that protect purchasing states and counties, and through them, the voters, from having to cast votes on systems that have not been properly vetted by the EAC. ES&S has repeatedly advertised its DS200 with internal modem—a critical component to ES&S's voting systems—as being EAC certified when, in fact, it is not. We therefore again respectfully request that EAC investigate and take action to correct this serious issue.

Sincerely,

Courtney Hostetler, Counsel  
Ronald A. Fein, Legal Director  
John C. Bonifaz, President  
Ben T. Clements, Chair of the Board  
Free Speech For People  
1320 Centre St. #405  
Newton, MA 02459  
(617) 249-3015  
[chostetler@freespeechforpeople.org](mailto:chostetler@freespeechforpeople.org)

Susan Greenhalgh  
Vice President of Policy and Program  
National Election Defense Coalition



## **ATTACHMENT A**



# DS200<sup>®</sup>

## *Precinct Scanner & Tabulator*



### *Protective Cover*

Cover has heavy-duty rubber seal to shelter DS200 from elements during transport.

### *Easy to Set Up*

Lid-up, power-on approach allows poll workers to easily open polls.

### *Touch Screen and Display*

Provides voters with instructions and immediate feedback. Tension bearings hold screen in place for custom positioning.

### *Ballot/Card Slot*

Voters cast both ballots and vote summary cards here; accommodates up to 19-inch ballots.

### *Auxiliary Ballot Compartment*

### *Main Ballot Compartment*

Easy, hassle-free storage of up to 2,500 ballots.

# 11

The number of 14-inch flat ballots processed per minute

# DS200 Key Features

The DS200 is a precinct-based scanner and vote tabulator equipped with the latest in ES&S' patented technology. Fully certified and compliant with EAC guidelines, the DS200 enhances the voting experience for voters and election officials alike. Our patented IMR® and PTRAC® technology ensures even the most poorly marked ballots are read accurately and consistently — protecting voter intent. All of this is designed to make everyone's job easier.

## ACCURATE



The DS200 combines the ES&S-patented Intelligent Mark Recognition (IMR®) and patented Positive Target Recognition & Alignment Compensation (PTRAC®) systems to accurately track and pinpoint target locations. This technology accommodates ballots inserted at angles or with erroneous marks to uphold voter intent. This precision improves the reliability of elections.

## SECURE



Like all ES&S tabulation equipment, the DS200 includes physical security features such as locking panels and security seals to secure sensitive components and election files, and a key-locked case for transport and shipping. The DS200 operating system controls, limits and detects unauthorized access to all critical data. The system also includes safeguards, such as data encryption and digital signatures, that help protect sensitive data and verify authenticity, including certification of all firmware.

## RELIABLE



Having both battery backup and thermal paper means you never have to worry about power outages or printer ink.

## COMPATIBLE



Works in conjunction with:

- ExpressVote® Universal Voting System
- Electionware® Election Management Software
- DS450® High-Throughput Scanner & Tabulator
- AutoMARK® Ballot Marking Device
- DS850® High-Speed Scanner & Tabulator
- Election Reporting Manager®

## COMPREHENSIVE

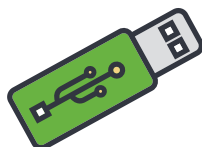

- Optional wireless modem results transfer with encryption
- Backup data storage
- Primary data storage device
- Data sent via Secure File Transfer Protocol (SFTP) server

## **ATTACHMENT B**

## PRECINCT SCANNER AND TABULATOR

# DS200<sup>®</sup>

### BECAUSE WHO WANTS TO BE STUCK INSIDE COUNTING BALLOTS?

The DS200 is a precinct-based scanner and vote tabulator equipped with the latest in ES&S' patented technology to make your job easier. Fully certified and compliant with EAC guidelines, the DS200 enhances the voting experience for voters and officials alike.

Our patented IMRT<sup>™</sup> and PTRAC<sup>™</sup> technology ensures even the most poorly marked ballots are read accurately and consistently — protecting voter intent. This technology greatly reduces time spent manually adjudicating as it automatically verifies voter marks.

Intelligent, integrated, digital, patented, flexible, easy to use, reliable, secure, certified and accessible – the DS200 is the answer to your precinct-level election needs.



# Faster election results and greater voter confidence



## KEY FEATURES

### LARGE CAPACITY

Handles up to 9,900 precincts for early voting needs.

### SPEED

Completely processes both sides of a ballot in six seconds or less. Handles bent or folded ballots with ease.

### ACCURACY

DS200 combines the ES&S patented Positive Target Recognition & Alignment Compensation (PTRAC™) and patented Intelligent Mark Recognition (IMR™) systems to positively track and pinpoint target locations, accommodating for ballots inserted at irregular angles or with erroneous marks to create unparalleled accuracy in determining voter intent. This accuracy improves the reliability of elections.

### ACCESSIBILITY

Compatible with the ES&S ExpressVote® Universal Voting System and AutoMARK® Americans with Disabilities Act (ADA)-compliant ballot-marking device.

### RELIABILITY

Battery backup in case of a power outage and thermal paper means you never have to worry about power outages or running out of printer ink.

### COMPATIBILITY

Works in conjunction with ES&S' Electionware® and Election Reporting Manager® software, ADA-compliant marking devices (AutoMARK® or ExpressVote®), the DS450™ and DS850® central scanner and tabulators and plastic or metal ballot bins to provide a complete end-to-end election solution.

### AVAILABLE OPTIONS

Wireless modem and capacity to send data via Secure File Transfer Protocol (SFTP) server; backup data storage in addition to being a primary data storage device.

## **ATTACHMENT C**



# ENHANCING THE ELECTION PROCESS FOR THE STATE OF RHODE ISLAND



## REQUEST FOR PROPOSAL RFP #9549934 VOTING EQUIPMENT SYSTEM

October 30, 2015

ORIGINAL



State of Rhode Island and Providence Plantations  
Department of Administration  
Division of Purchases

**RIVIP BIDDER CERTIFICATION COVER FORM**  
**SECTION 1 - BIDDER INFORMATION**

*Bidder must be registered as a vendor on the RIVIP system at [www.purchasing.ri.gov](http://www.purchasing.ri.gov) to submit a bid proposal.*

**Solicitation Number:** 7549934  
**Solicitation Title:** RFP-VOTING EQUIPMENT SYSTEM (81 pages)

**Bid Proposal Submission  
Deadline Date & Time:** 10/30/2015 10:00 AM

**RIVIP Vendor ID #:** 18999  
**Bidder Name:** Election Systems And Software  
**Address:** 11208 John Galt Blvd.  
Omaha , NE 68137  
USA

**Telephone:** 402-938-1440  
**Fax:** 402-970-1276  
**Contact Name:** Tamara Kaup  
**Contact Title:** Manager of Proposals  
**Contact Email:** bids@essvote.com

**SECTION 2 —DISCLOSURES**

**Bidders must respond to every statement. Bid proposals submitted without a complete response may be deemed nonresponsive.**

*Indicate "Y" (Yes) or "N" (No) for Disclosures 1-4, and if "Yes," provide details below. Complete Disclosure 5. If the Bidder is publicly held, the Bidder may provide owner information about only those stockholders, members, partners, or other owners that hold at least 10% of the record or beneficial equity interests of the Bidder.*

- N   1. State whether the Bidder, or any officer, director, manager, stockholder, member, partner, or other owner or principal of the Bidder or any parent, subsidiary, or affiliate has been subject to suspension or debarment by any federal, state, or municipal governmental authority, or the subject of criminal prosecution, or convicted of a criminal offense within the previous 5 years. If "Yes," provide details below.
- N   2. State whether the Bidder, or any officer, director, manager, stockholder, member, partner, or other owner or principal of the Bidder or any parent, subsidiary, or affiliate has had any contracts with a federal, state, or municipal governmental authority terminated for any reason within the previous 5 years. If "Yes," provide details below.
- N   3. State whether the Bidder, or any officer, director, manager, stockholder, member, partner, or other owner or principal of the Bidder or any parent, subsidiary, or affiliate has been fined more than \$5000 for violation(s) of any Rhode Island environmental law(s) by the Rhode Island Department of Environmental Management within the previous 5 years. If "Yes," provide details below.

- N 4. State whether any officer, director, manager, stockholder, member, partner, or other owner or principal of the Bidder is serving or has served within the past two calendar years as either an appointed or elected official of any state governmental authority or quasi-public corporation, including without limitation, any entity created as a legislative body or public or state agency by the general assembly or constitution of this state.
5. List each officer, director, manager, stockholder, member, partner, or other owner or principal of the Bidder, and each intermediate parent company and the ultimate parent company of the Bidder. For each individual, provide his or her name, business address, principal occupation, position with the Bidder, and the percentage of ownership, if any, he or she holds in the Bidder, and each intermediate parent company and the ultimate parent company of the Bidder.

*Disclosure details (continue on additional sheet if necessary):*

**Management Board**

\* Aldo Tesi - Chairman, Election Systems & Software, LLC, 11208 John Galt Boulevard, Omaha, NE 68137

\* Michael R. McCarthy - Board Member of ES&S, Chairman of McCarthy Group, LLC, 1601 Dodge Street, Suite 3800, Omaha, NE 68102

Officers (all located at Election Systems & Software, LLC, 11208 John Galt Boulevard, Omaha, NE 68137)

Thomas E. Burt - President and Chief Executive Officer; Thomas F. O'Brien - Executive Vice President, Finance, Treasurer and Chief Financial Officer; Kathy Rogers - Senior Vice President, Government Relations; Ken Carbullido - Senior Vice President, Innovations; Matthew Nelson -

Senior Vice President, Sales; Jim Schmidt - Senior Vice President, Manufacturing; Richard Jablonski - Vice President, Finance and Secretary;

Steve Bolton - Vice President, Intellectual Property; Gary Weber - Vice President, Software Development; Eric Anderson - Vice President/General

Counsel; Steve Pearson - Vice President, Certification; Adam Carbullido - Vice President, Release Management; Michele Feichtinger-Ernst - Vice

President, Customer Service

Parent Company to ES&S - Government Systems, Software & Services, Inc. (Owns 100% of ES&S)

### SECTION 3 —CERTIFICATIONS

**Bidders must respond to every statement. Bid proposals submitted without a complete response may be deemed nonresponsive.**

*Indicate "Y" (Yes) or "N" (No), and if "No," provide details below.*

**THE BIDDER CERTIFIES THAT:**

- Y 1. The Bidder will immediately disclose, in writing, to the State Purchasing Agent any potential conflict of interest which may occur during the term of any contract awarded pursuant to this solicitation.
- Y 2. The Bidder possesses all licenses and anyone who will perform any work will possess all licenses required by applicable federal, state, and local law necessary to perform the requirements of any contract awarded pursuant to this solicitation and will maintain all required licenses during the term of any contract awarded pursuant to this solicitation. In the event that any required license shall lapse or be restricted or suspended, the Bidder shall immediately notify the State Purchasing Agent in writing.
- Y 3. The Bidder will maintain all required insurance during the term of any contract pursuant to this solicitation. In the event that any required insurance shall lapse or be canceled, the Bidder will immediately notify the State Purchasing Agent in writing.
- Y 4. The Bidder understands that falsification of any information in this bid proposal or failure to notify the State Purchasing Agent of any changes in any disclosures or certifications in this Bidder Certification may be grounds for suspension, debarment, and/or prosecution for fraud.
- Y 5. The Bidder has not paid and will not pay any bonus, commission, fee, gratuity, or other remuneration to any employee or official of the State of Rhode Island or any subdivision of the State of Rhode Island or other governmental authority for the purpose of obtaining an award of a contract pursuant to this solicitation. The Bidder further certifies that no bonus, commission, fee, gratuity, or other remuneration has been or will be received from any third party or paid to any third party contingent on the award of a contract pursuant to this solicitation.
- Y 6. This bid proposal is not a collusive bid proposal. Neither the Bidder, nor any of its owners, stockholders, members, partners, principals, directors, managers, officers, employees, or agents has in any way colluded, conspired, or agreed, directly or indirectly, with any other bidder or person to submit a collusive bid proposal in response to the solicitation or to refrain from submitting a bid proposal in response to the solicitation, or has in any manner, directly or indirectly, sought by agreement or collusion or other communication with any other bidder or person to fix the price or prices in the bid proposal or the bid proposal of any other bidder, or to fix any overhead, profit, or cost component of the bid price in the bid proposal or the bid proposal of any other bidder, or to secure through any collusion, conspiracy, or unlawful agreement any advantage against the State of Rhode Island or any person with an interest in the contract awarded pursuant to this solicitation. The bid price in the bid proposal is fair and proper and is not tainted by any collusion, conspiracy, or unlawful agreement on the part of the Bidder, its owners, stockholders, members, partners, principals, directors, managers, officers, employees, or agents.
- Y 7. The Bidder: (i) is not identified on the General Treasurer's list created pursuant to R.I. Gen. Laws § 37-2.5-3 as a person or entity engaging in investment activities in Iran described in § 37-2.5-2(b); and (ii) is not engaging in any such investment activities in Iran.
- Y 8. The Bidder will comply with all of the laws that are incorporated into and/or applicable to any contract with the State of Rhode Island.

Certification details (continue on additional sheet if necessary):

---

---

---

---

---

---

---

---

---

---

---

---

---

---

---

---

---

---

---

---

---

---

---

---

---

---

Submission by the Bidder of a bid proposal pursuant to this solicitation constitutes an offer to contract with the State of Rhode Island through the Division of Purchases on the terms and conditions contained in this solicitation and the bid proposal. The Bidder certifies that: (1) the Bidder has reviewed this solicitation and agrees to comply with its terms and conditions; (2) the bid proposal is based on this solicitation; and (3) the information submitted in the bid proposal (including this Bidder Certification Cover Form) is accurate and complete. The Bidder acknowledges that the terms and conditions of this solicitation and the bid proposal will be incorporated into any contract awarded to the Bidder pursuant to this solicitation and the bid proposal. The person signing below represents, under penalty of perjury, that he or she is fully informed regarding the preparation and contents of this bid proposal and has been duly authorized to execute and submit this bid proposal on behalf of the Bidder.

**BIDDER**

Date: 10/27/2015

Election Systems & Software, LLC  
Name of Bidder  
  
Signature in ink  
Richard J. Jablonski, Vice President, Finance  
Printed name and title of person signing on behalf of Bidder

second to none and will provide invaluable during the implementation and first use of a new voting system.

- **Certified Proven Products** – ES&S is bidding the proven DS200 precinct based scanner. With more than 25,000 DS200's in use in 16 states and successfully tabulating millions of votes in jurisdictions like New York City, Miami and Minneapolis not to mention the states of Maine and Maryland, Rhode Island will be utilizing the industry's number 1 digital precinct solution..

Today, not only do we work with many of the same customers we've supported for more than three decades, but our business has grown to serve 41 states and includes more than 4,500 clients. From our humble beginnings supporting a handful of election administrators and voters in 1979, our election equipment and software is now utilized by approximately 60% of the registered voters in the United States (see the figure that follows; Jurisdictions Using ES&S Equipment and Software are shown in dark blue).

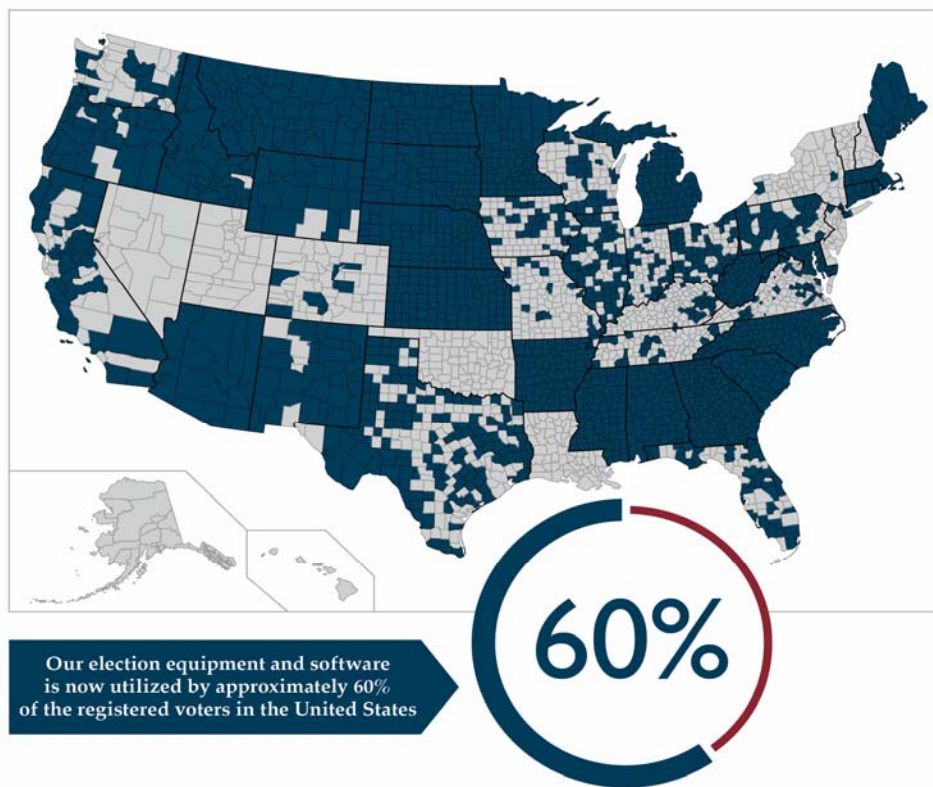

Years of service



States supported



Clients supported

---

**2. Vendor must provide the following information for verification of completion of VSTL certification:**

- Name, address, and telephone number of VSTL performing certification test
- Date of certification

**ES&S RESPONSE**

The base system, EVS,5.2.0.3, was VSTL tested by:

National Technical Systems (NTS)  
7800 Hwy 20 West  
Huntsville, AL 35806  
256-837-4411

Date of VSTL Certification: July 22, 2015

Additional components not part of the Election Assistance Commission's certification process, including wireless transmission of election results were VSTL tested by NTS and certified August 21, 2015.

---

**3. Provide a flow chart of the entire System and how each component integrates into it.**

**ES&S RESPONSE**

Please see **Attachment B** for a flow chart of the system.

---

**4. Describe any components of your system that are not part of the Elections Assistance Commission's certification process including but not limited to the wireless transmission of election results.**

**ES&S RESPONSE**

The following components are not part of the EAC's certification process:

- Electionware Toolbox – provides ballot test decks for L&A testing
- Modem transmission of results from the 9 towns with DS200's with wireless modems to the Central Tabulation Equipment (Voting System Test Lab (VSTL) Tested)
- The Firewall and Communications Server at the State Board of Elections that will receive the DS200 results transmissions from the DS200's with wireless modems at the 9 towns (VSTL Tested)
- The remote connection of Election Reporting Manager workstations at the 30 Regional Tabulation Equipment sites. The Election Reporting Manager application used at the Regional Tabulation Equipment sites is EAC certified.
- Ballot-on-demand Balotar printers
- Small and medium-sized font for printing on ExpressVote vote summary cards.

9. Describe if a voted ballot that contains a crease or other type of fold mark can be read by the precinct count unit and the central mail ballot counting unit. Attach individual ballots that can be read by a precinct count unit and central mail ballot counting unit containing a sample of creases and fold marks.

### ES&S RESPONSE

Yes, a voted ballot that contains a crease or other type of fold mark can be read by the precinct count unit and the central mail ballot counting unit. Both the DS200 and DS850 have been uniquely designed to accept ballots that have been folded. The paper transports on both scanners safely guide previously folded ballots through the read heads to avoid paper jams or misreads and the scan speed approaches the processing speed for unfolded ballots. The DS850 uses a patented technology known as TruGrip™, to provide constant contact with each ballot. By using 22 axled, double-rollers, full control of the ballot is ensured from start to finish. A close-up of the DS850 TruGrip rollers is shown below:

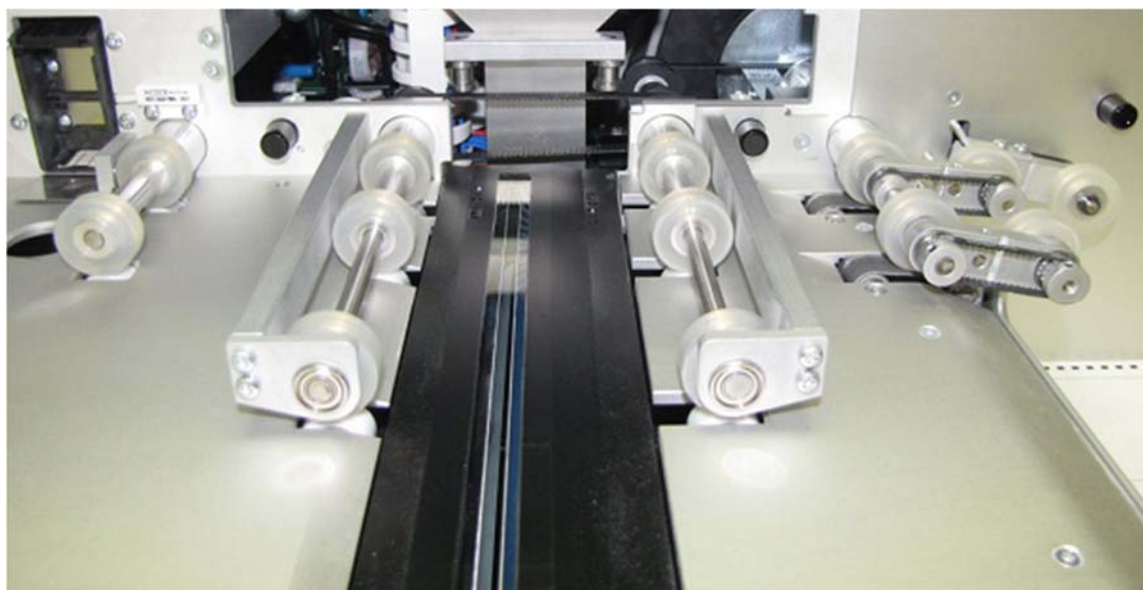

Sample ballots are attached as [Attachment E](#).

10. Describe what security measures are available to protect the operating system, application programs and data on all System equipment from unauthorized change.

### ES&S RESPONSE

From concept to construction, ES&S adheres to industry-leading standards for quality and security.

Designed and federally certified to meet the rigorous security standards of the 2005 Voluntary Voting System Guidelines, the operating system controls, limits, and detects unauthorized access to all critical system components. The system also implements state-of-the-art safeguards against losses of system integrity, availability, confidentiality and accountability.

## PREVIOUS EXPERIENCE AND BACKGROUND

### PREVIOUS EXPERIENCE AND BACKGROUND – EQUIPMENT VENDOR

*1. Provide the history of the proposed System, including whether the System proposed is the latest version of the equipment available that has been fully tested and currently in distribution.*

#### **ES&S RESPONSE**

The DS200 was first manufactured in April 2007. By November 2008, more than 4,500 DS200 digital precinct scanners were built and successfully used in the Florida Primary and General elections. ES&S utilized Ricoh Electronics Inc. as its prime contract manufacturer for the DS200 from 2007-2009.

In 2009, the EAC certified the DS200 under 2002 Voting System Standards. During 2009, more than 8,000 DS200 digital scanners were successfully used in the primary and general elections in Florida and Ohio. In 2009, ES&S shifted responsibility for contract manufacturing to Pivot International, Inc, headquartered out of Lenexa, Kansas. Pivot conducts manufacturing operations out of its ISO 9001 certified facility in Manila, Republic of the Philippines.

In 2010 New York City, selected ES&S to provide DS200 digital scanners to support its 4.6 million voters. Five other counties in New York also chose the DS200 as their primary voting system. In 2012, the State of New York certified the DS200 under the 2005 Voluntary Voting Systems Guidelines (VVSG) and New York election law requirements. Less than a year later, in May 2013, the U.S. Election Assistance Commission (EAC) approved the certification of the DS200 under the 2005 VVSG standards.

As of today, ES&S has manufactured more than 24,000 DS200 scanners. By the end of 2015, ES&S will manufacture an additional 4,000 DS200 units bringing the total produced since the first build to over 21,000.

Today, more than 50 million registered voters in the United States and Canada can now cast their ballots via this state-of-the-art ballot scanner.

The proposed version of the DS200 is the latest version of the DS200 which is certified to the U.S. EAC VVSG 2005 standard and includes many enhancements in the areas of security, ballot processing speed, ballot handling, and voter and poll worker graphical interfaces.

The DS850 was first manufactured in 2009. The DS850 was first used in Colorado Springs Colorado in May of 2010. ES&S utilized DATAWIN Inc. as its prime contract manufacturer for the DS850.

In 2012, the EAC certified the DS850 under 2002 Voting System Standards. From 2009 to 2015 170 DS850 have been manufactured by DATAWIN, and are in use over 20 states from coast to coast

The DS850 was design to span the EAC standards and was also certified to the U.S. EAC VVSG 2005 standard.

The ExpressVote was first manufactured in 2014. By September of 2015, more than 5000 ExpressVotes were built and successfully deployed to customers across the US. Pivot International, Inc, headquartered out of Lenexa, Kansas is the original and current manufacture for the ExpressVote. Pivot conducts manufacturing operations out of its ISO 9001 certified facility in Manila, Republic of the Philippines.

The current ExpressVote was certified to U.S. EAC VVSG 2005.

**Rhode Island EVS 5.2.0.3/5.3.0.3  
 Statewide Network System Configuration**

Legend

- EAC Certified Configuration
- Extended Configuration

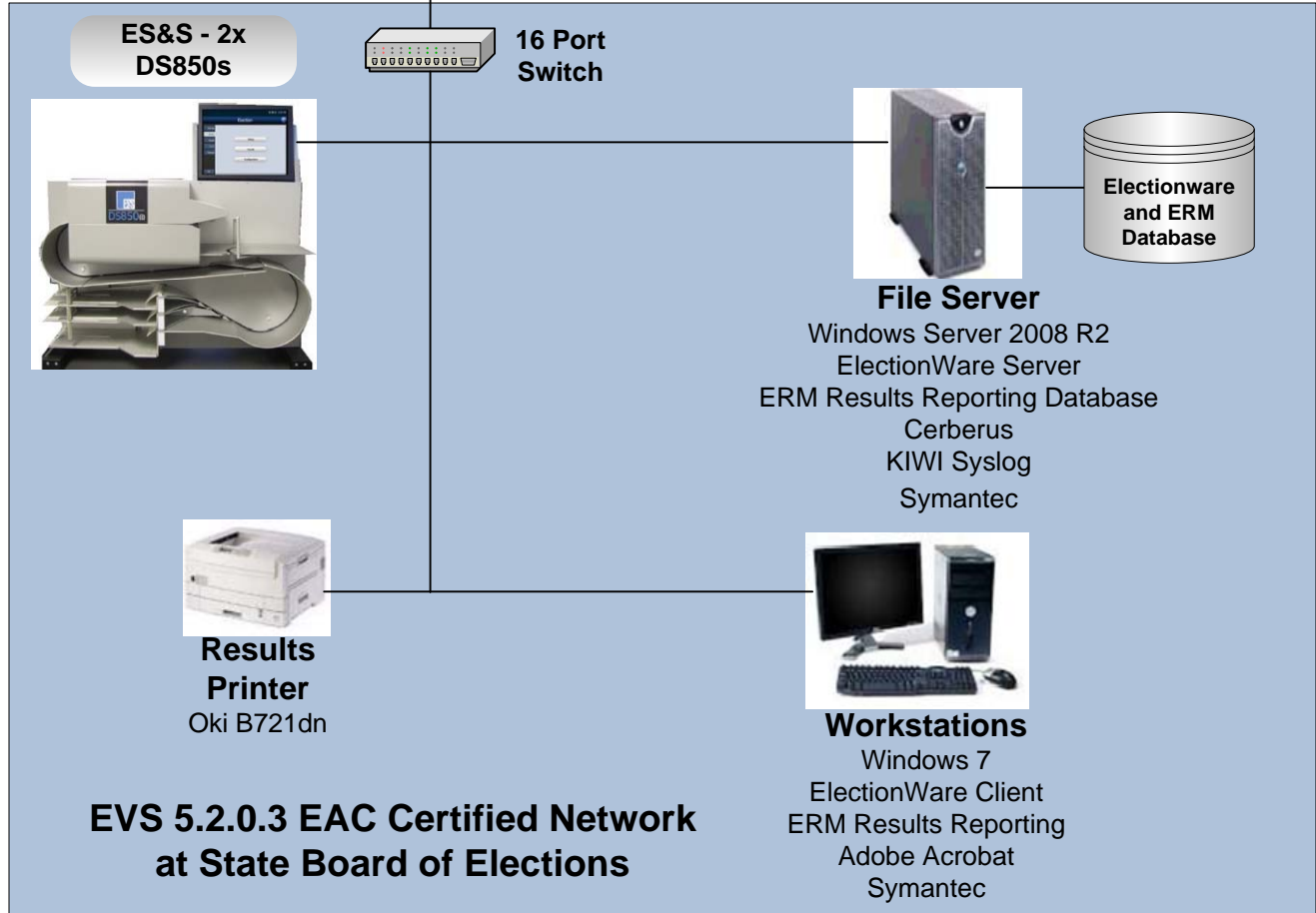
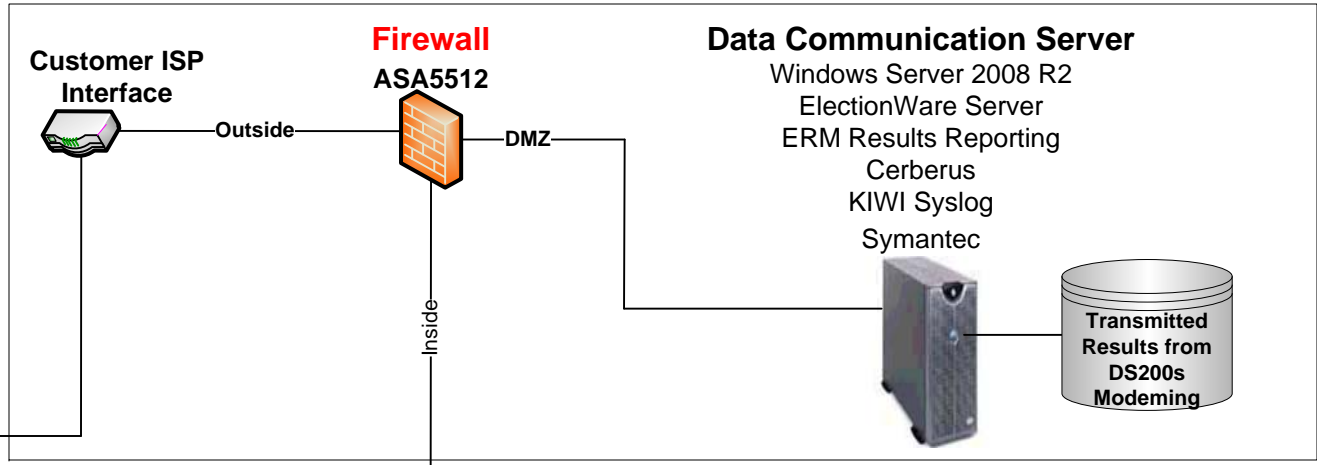
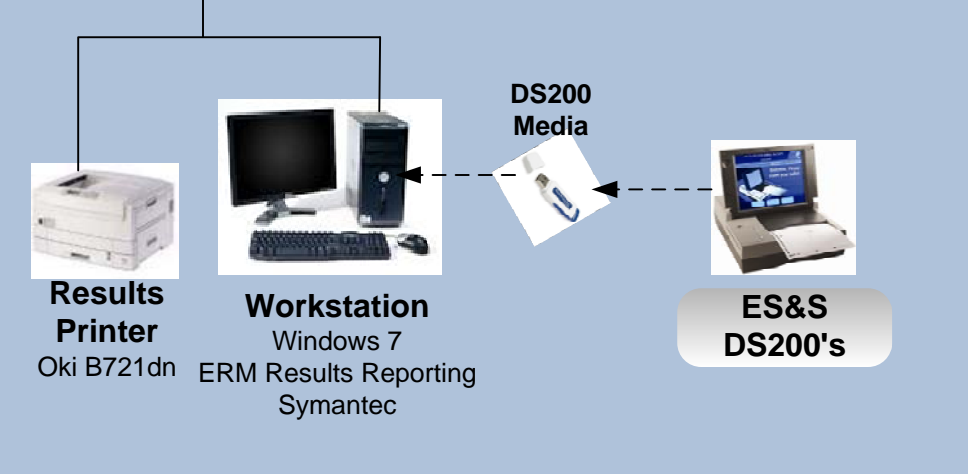
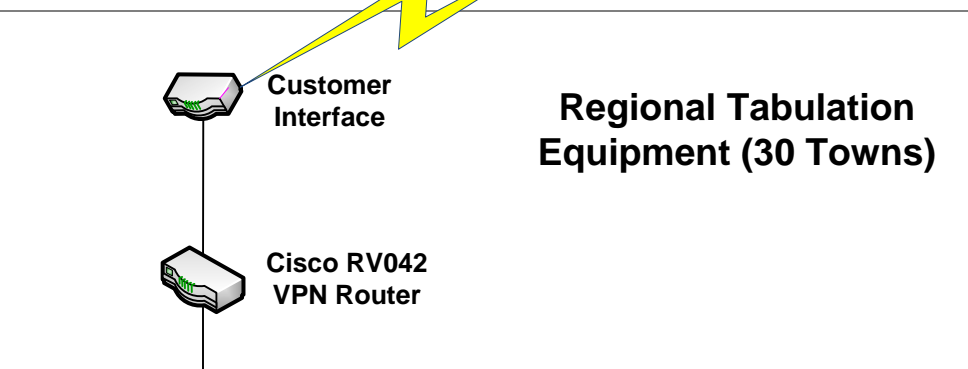
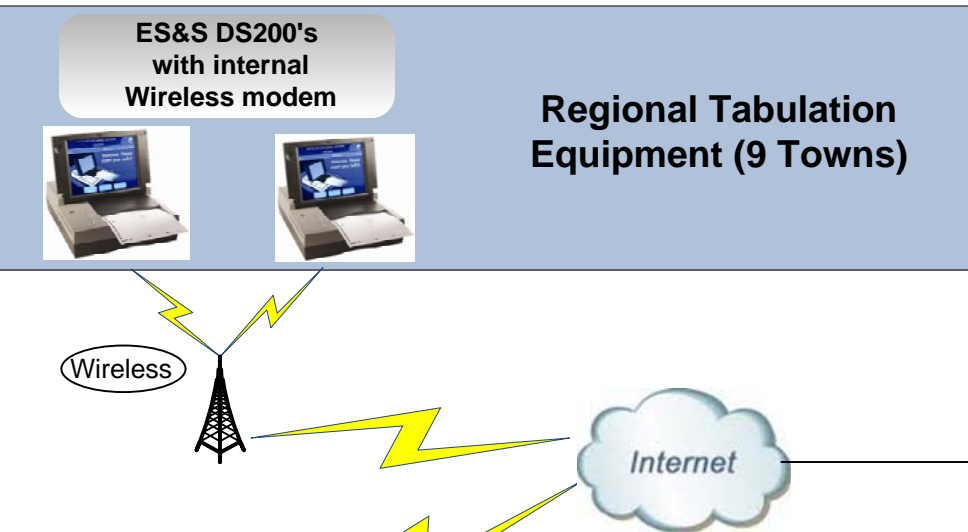



**State of Rhode Island EVS 5.2.0.3/5.3.0.3  
DS200 Modeming System Configuration**

Legend

EAC Certified Configuration

Extended Configuration

**Regional Tabulation Equipment (9 Towns)**

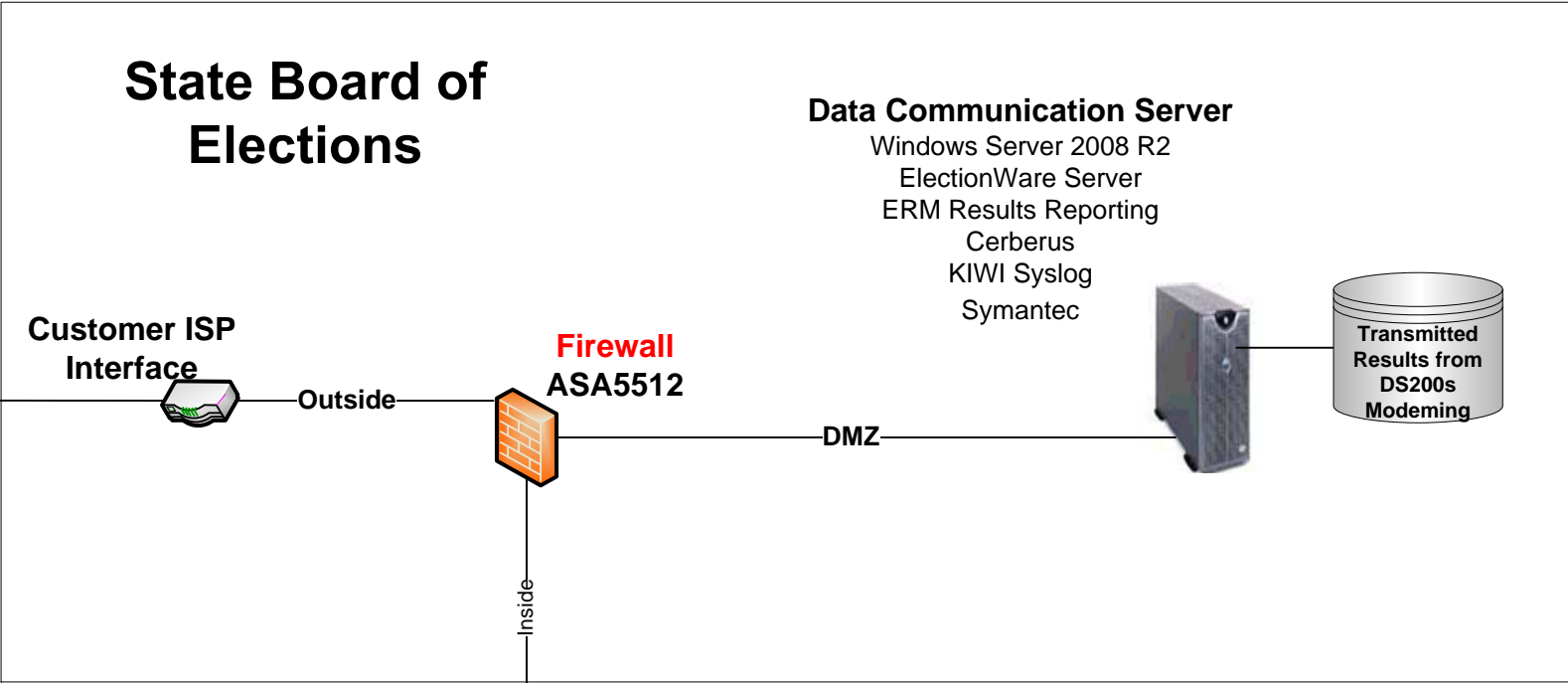

**ES&S DS200's with internal Wireless modem**

9 Cities, Towns or Villages using a wireless modem in the DS200s to transmit results to the BOE Office

